

Elevation View

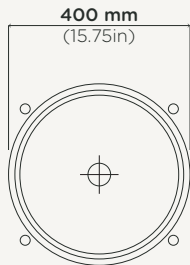

Plan View

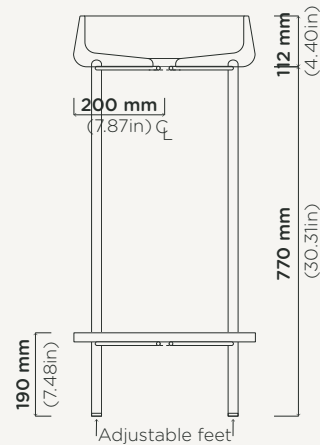

Section View

Funl Basin Stand

Material	Ultra High Performance Concrete (UHPC)
Weight	21kg (46lbs)
Dimensions	D400mm x H882mm (D15.75in x H34.72in)
Bowl Capacity	8.4L (2.97gal)
Waste	32mm (1.25in) or 40mm (1.50in) Standard Non-Overflow Waste Only (Not Supplied by Nood Co)
Warranty	Refer to Warranty for specific information.
Install Guide	installnood.co
Options	White Frame / Black Frame
Installation	L Bracket and fixings provided to fit to wall, adjustable feet on all legs
Assembly	Frame (One Piece), Basin & Tray separate Instructions provided

For accurate colour matching, we recommend using our sample kits or visiting an authorised reseller. Natural variations and characteristics, such as patina and pinholes, are to be expected in concrete and do not constitute as defects. As this product is handmade, sizing is subject to slight variation.

[View Online](#)